

NDnano Undergraduate Research Fellowship (NURF) 2014 Project Summary

1. Student name: Matthew Henne

2. Faculty mentor name: Mark Wistey

3. Project title: Core-Shell Upconverting Nanostructures (CSUN)

4. Briefly describe any new skills you acquired during your summer research:

I worked extensively with MATLAB, running simulations and creating data plots. While I had worked with MATLAB in the past, working with this software all summer allowed me to refine my skills and become proficient. I also gained a valuable skill in performing literature searches, which allowed me to efficiently find useful information that I was able to apply to my project.

5. Briefly share a practical application/end use of your research:

The work I put in this summer will lay the groundwork for the rest of the project. My project showed that CSUN is theoretically possible and could improve the efficiency of a solar cell. Using the data I generated, we know what direction we want to go with this project, what areas we need to focus on, and what kind of results to expect.

Begin two-paragraph project summary here (~ one type-written page) to describe problem and project goal and your activities / results:

My project looked at increasing the efficiency of a solar cell using core-shell upconverting nanostructures (CSUN). CSUNs utilize two low-energy photons to excite one carrier into the conduction band. The basic structure is shown in Figure 1. The first photon absorbed excites an electron in the core from the valence band (VB) to the conduction band (CB). The second photon excites the electron from the conduction band of the core to the conduction band of the host. The electron becomes current. Using MATLAB, I coded a rate equation model that used an actual solar spectrum and calculated the rate at which photons are absorbed and excited into the conduction band.

I looked specifically at the case of a Ge core with AlGaAs alloys. Ge is advantageous because it has an indirect bandgap but with a direct valley at a slightly higher energy. This allows Ge to be a good absorber of light without being an emitter. Using these properties, I used rate equations to produce an estimation of power generated. From there, I looked at the power generated from the cores and explored how to maximize the efficiency. I tested different bandgaps for the core, shell, and host, different doping of the core, different thickness of the cores. I performed literature searches to explore different materials and geometries that could be advantageous. New ideas such as plasmon resonance were explored to see if it was applicable to our project. Among other things, we discovered that heavy n-type doping of the CSUN cores is important to produce a reasonable improvement in efficiency. These simulations showed that with reasonable doping and CSUN geometries, we could expect an increase in efficiency of >1%. This might not seem like a lot, but people are working really hard to get 1% increased in solar cells, especially for high efficiency multijunction solar cells.

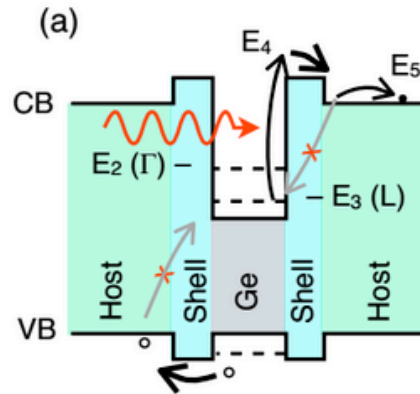

Figure 1. Energy bandgap of Ge core CSUN

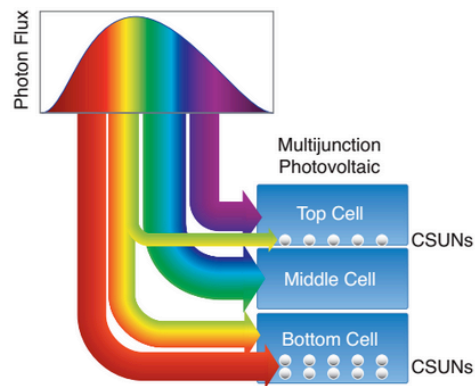

Figure 2. CSUN placement in multijunction solar cell

Publications (papers/posters/presentations):